

F SERIES

W3-1318SA

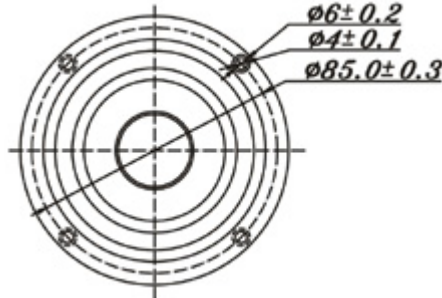
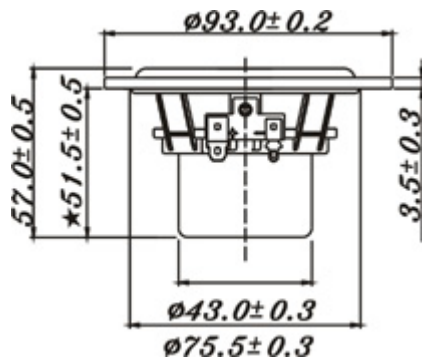

3" PAPER FULL RANGE

- FULL RANGE FREQUENCY RESPONSE
- HIGH POWER LOADING DESIGN
- DIE CAST BASKET, VC VENTED DESIGN
- BAMBOO FIBER PAPER CONE WITH SANTOPRENE SURROUND
- MAGNETICALLY SHIELDED
- UNDERHUNG MOTOR DESIGN
- LOW 2nd,3rd DISTORTION DESIGN



DIAPHRAGM MTL	Bamboo fiber paper
SURROUND MTL	Santoprene
NOMINAL IMPEDANCE	8 Ω
DCR IMPEDANCE	6.6 Ω
SENSITIVITY 1W/1m	86 dB
FREQUENCY RESPONSE	105-20K Hz
FREE AIR RESONANCE	105 Hz
VOICE COIL DIAMETER	25.4 mm
AIR GAP HEIGHT	8 mm
RATED POWER INPUT	15 W
MAXIMUM POWER INPUT	30 W
FORCE FACTOR, BL	4.69 TM
MAGNET WEIGHT (oz)	Neodymium
MOVING MASS	2.50 g
FERRO FLUID ENHANCED	No
SUSPENSION COMPL.	906.484 uMN ⁻¹
EFFEC.PISTON AREA	0.0032 M ²
Levc	0.011 mH
Zo	27 ohm
X-max	0.4 mm
Vas	1.32 Litr.
Qts	0.38
Qms	1.68
Qes	0.50



VOICE:886.2.26570282 FAX:886.2.26580166
E-MAIL :info@tb-speaker.com

CLOSE