

AMT[®] 2310c

AIR MOTION TRANSFORMER

TECHNICAL DATA	11.09
IMPEDANCE	8 OHM
RESONANCE FREQUENCY	1000 Hz
FREQUENCY RESPONSE	1 - 25 kHz
RECOMMENDED CROSSOVER	2000 Hz
SENSITIVITY	91 dB
POWERHANDLING SHORT TERM	./.
POWERHANDLING CONTINUOUSLY	./.
EFFECTIVE DIAPHRAGM AREA	19.7 cm ²
MAGNET MATERIAL	NEODYMIUM
TOTAL WEIGHT	0.5 kg
RECOMMENDED ENCLOSURE VOLUME	100 cm ³

TWEETER FOR 2- / 3-WAY LOUDSPEAKERS



ALSO WITH SILVER / RECTANGLE FACE PLATE

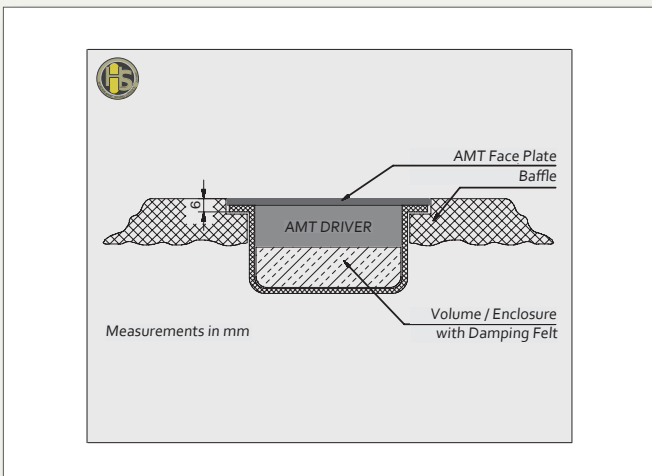

SECTION DRAWING / ENCLOSURE VOLUME

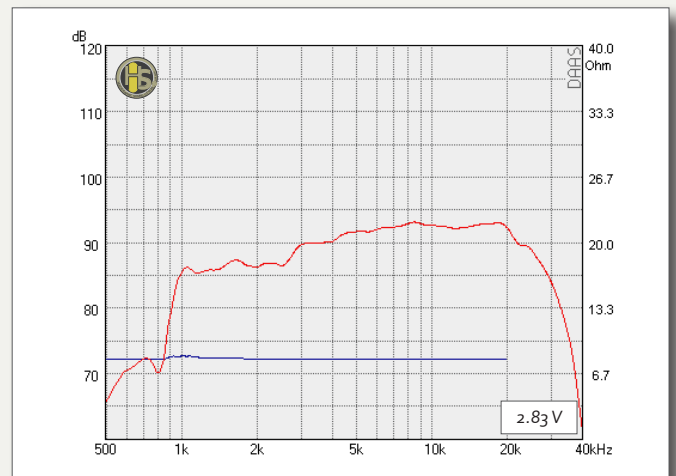

FREQUENCY RESPONSE @ 1W/1m

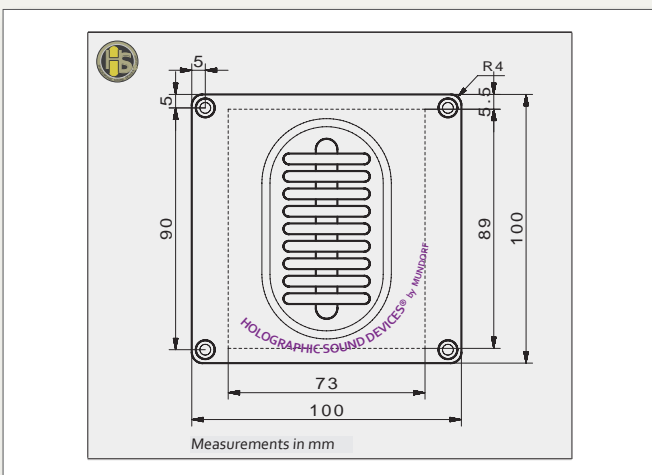

MEASUREMENTS RECTANGLE FACE PLATE

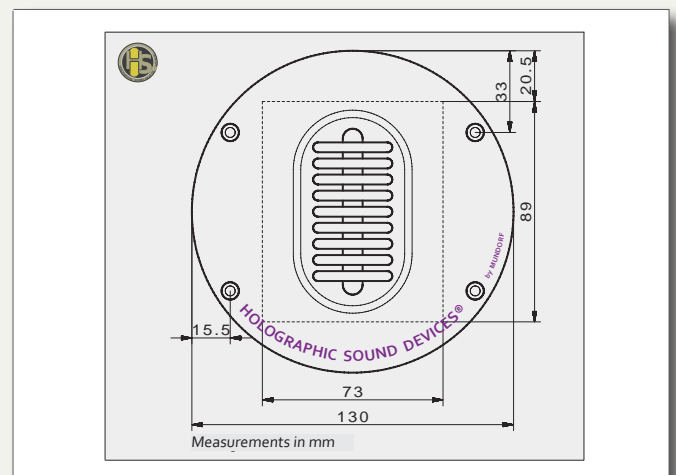

MEASUREMENTS CIRCULAR FACE PLATE

>>> **HOLOGRAPHIC SOUND DEVICES[®] by MUNDORF** provides AMT[®] (Air Motion Transformer) from its own deployment and manufacturing since 2004. By now, they are well-established in the top line speaker systems

of many notable manufacturers. The present AMT[®] concert model 2310c now provides the advantages of the Air Motion principle also to quasi-professional speaker builder at state-of-the-art level in >>>

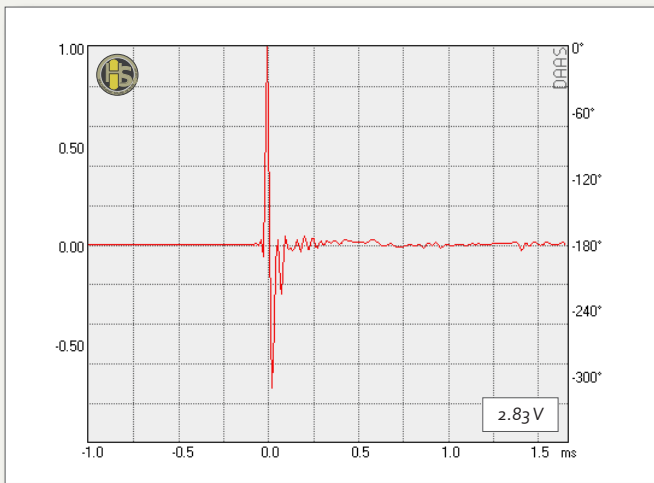

IMPULSE STEP RESPONSE @ 1W/1m

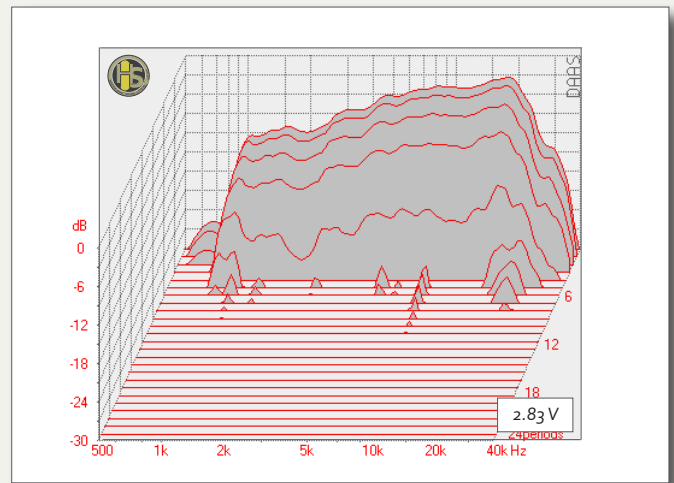

WATERFALL DIAGRAM @ 1W/1m

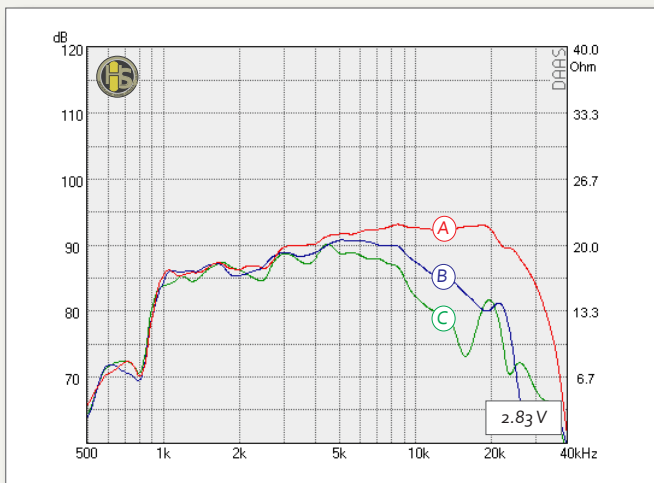

FQ RESPONSE @ A:0° B:60° C:90° HORIZONTAL

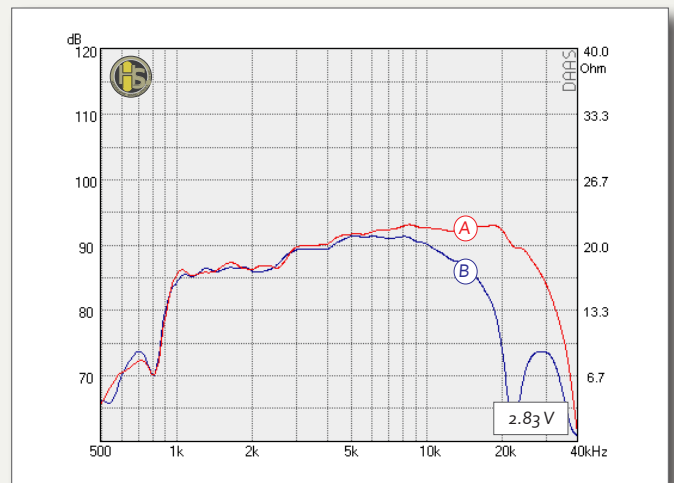

FQ RESPONSE @ A:0° B:30° VERTICAL

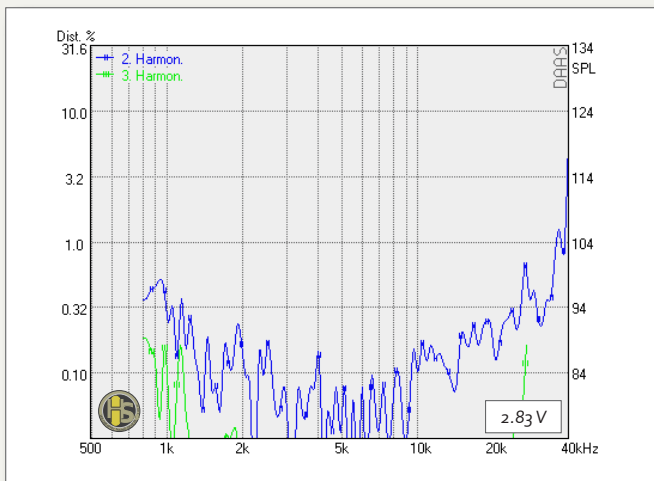

DISTORTION RATIO IN % @ 1W/1m

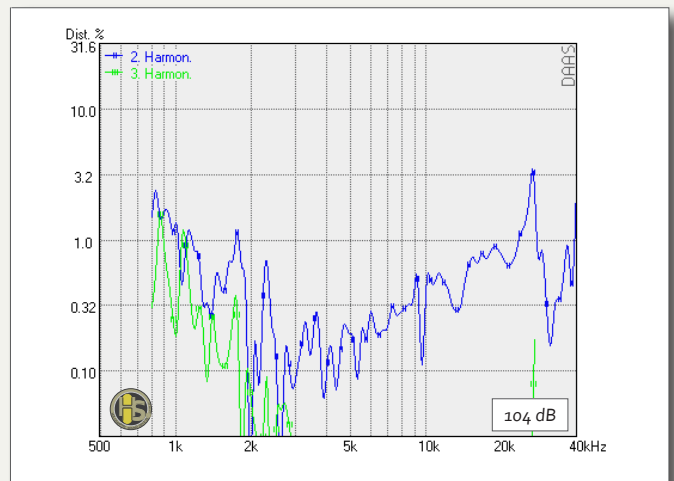

DISTORTION RATIO IN % @ 104dB/SPL

terms of the latest audio developments and most advanced material and, manufacturing technologies respectively. I.g., coating with the strong Neodymium magnets the low mass diaphragm foil not only renders highest efficiency and finest micro dynamik but a remarkable high SPL at an absolute low distortion ratio, same time.

For the holographically precise depth of clearance and transparency of its music performance stands -beside the AMT®principle inherent cylindrical wave

front- most painstaking craftsmanship, CAM backed function control plus an eventually matched pair at lowest tolerances according to the final measurement.

All AMT®concert models feature a particularly designed low resonance volume which is carefully damped with differently responding multiple layers of felt. Understood, internally the volume is connected with finest SilverGold wires destinating in gold-plated banana sockets to which the appropriate plugs are delivered, too.

