

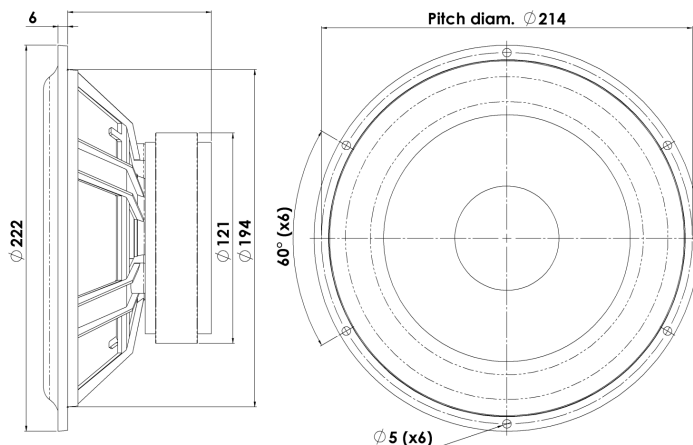

## WOOFER

## 21W/8555-00

The Symmetric Drive (SD-1) concept with copper in the magnet system was invented by Scan-Speak. High-quality magnet system design has thus been a key feature of Scan-Speak design since the companys inception. The Classic woofers are highly praised, and are used in some of the worlds most exceptional high-end loudspeakers. Some feature Kevlar cones, others have the innovative carbon fibre paper cones.



### KEY FEATURES:

- Patented Symmetrical Drive Motor Design
- Low-Loss linear suspension
- Low Damping SBR Rubber Surround
- Low Resonance Freq. 20Hz
- Air Dried Paper/Carbon Fibre Cone
- 42mm Voice Coil

#### T-S Parameters

Resonance frequency [fs]	20 Hz
Mechanical Q factor [Qms]	4.50
Electrical Q factor [Qes]	0.33
Total Q factor [Qts]	0.31
Force factor [Bl]	8.2 Tm
Mechanical resistance [Rms]	0.89 kg/s
Moving mass [Mms]	32 g
Suspension compliance [Cms]	1.98 mm/N
Effective diaph. diameter [D]	167 mm
Effective piston area [Sd]	220 cm <sup>2</sup>
Equivalent volume [Vas]	134 l
Sensitivity (2.83V/1m)	87 dB
Ratio Bl/√Re	3.50 N/√W
Ratio fs/Qts	65 Hz

#### Notes:

IEC specs. refer to IEC 60268-5 third edition.  
All Scan-Speak products are RoHS compliant.  
Data are subject to change without notice.  
Datasheet updated: February 22, 2011.

#### Electrical Data

Nominal impedance [Zn]	8 Ω
Minimum impedance [Zmin]	6.4 Ω
Maximum impedance [Zo]	80.5 Ω
DC resistance [Re]	5.5 Ω
Voice coil inductance [Le]	0.4 mH

#### Power Handling

100h RMS noise test (IEC 17.1)	100 W
Long-term max power (IEC 17.3)	- W

#### Voice Coil and Magnet Data

Voice coil diameter	42 mm
Voice coil height	19 mm
Voice coil layers	2
Height of gap	6 mm
Linear excursion	± 6.5 mm
Max mech. excursion	± 12 mm
Unit weight	2.2 kg



CLASSIC

# WOOFER

21W/8555-00

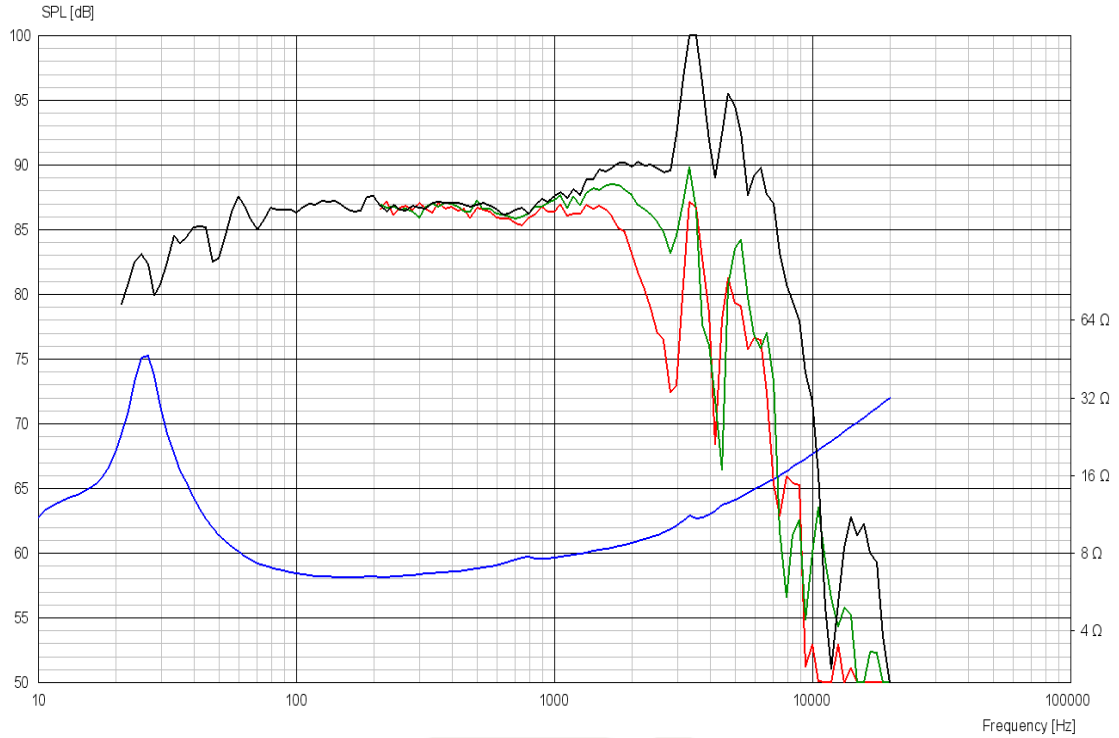

## Advanced Parameters (Preliminary)

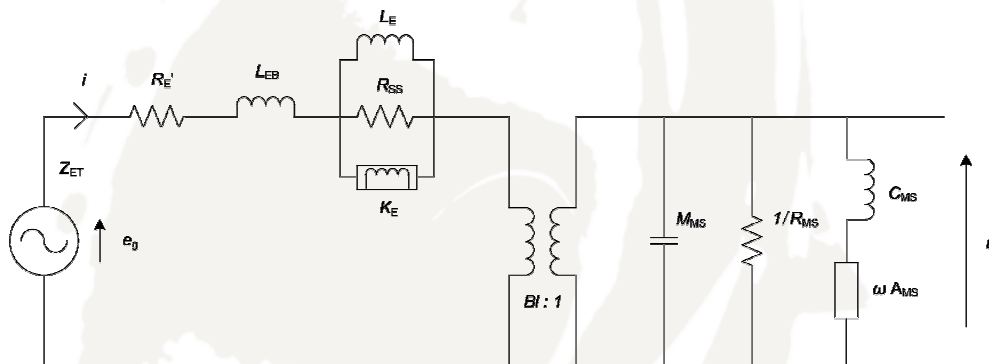

### Electrical data:

Resistance [Re']	5.77 Ω
Free inductance [Leb]	0.152 mH
Bound inductance [Le]	1.03 mH
Semi-inductance [Ke]	0.0308 SH
Shunt resistance [Rss]	2289 Ω

### Mechanical Data

Force Factor [Bl]	7.25 Tm
Moving mass [Mms]	32.8 g
Compliance [Cms]	2.14 mm/N
Mechanical resistance [Rms]	0.155 kg/s
Admittance [Ams]	0.293 mm/N

