

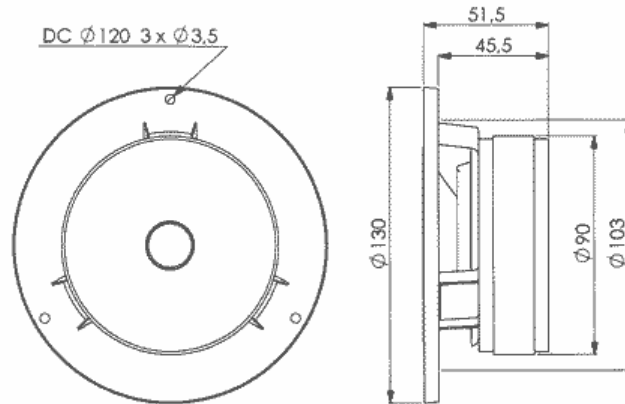

13M/8640-00

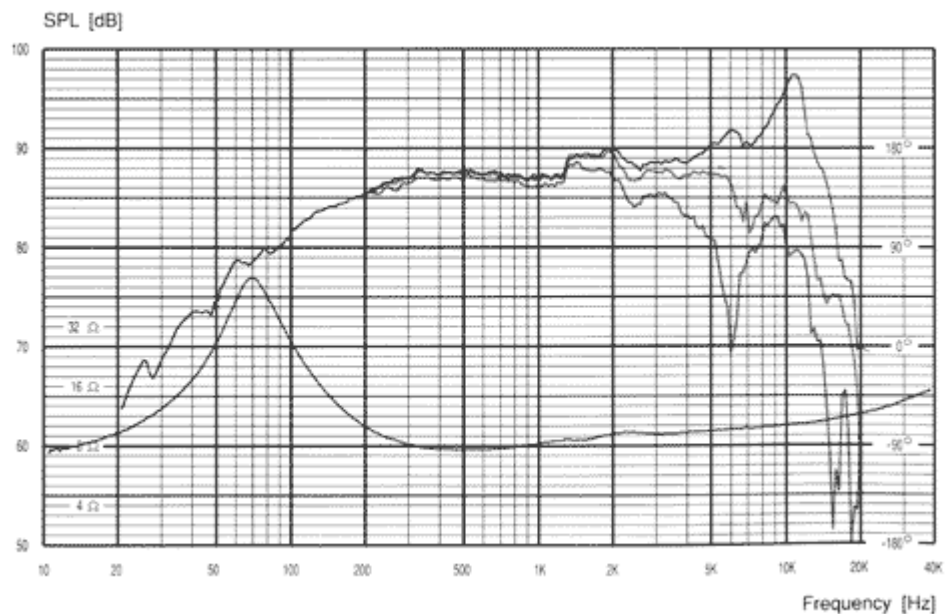

Characteristic sensitivity (2.83V / 1m)	: 87.5 dB
Recommended frequency range	: 300 - 8000 Hz
Free air resonance frequency, f_s	: 64 Hz
DC resistance, R_e	: 5.8 ohm
Voice coil inductance, L_e	: 0.1 mH
Effective piston area, S_d	: 48 cm ²
Moving mass incl. air, m_d	: 4.1 g
Mechanical loss, R_m	: 0.6 Ns/m
Force factor, BL	: 6.0 Tm
Equivalent volume, V_{as}	: 5 ltr.
Mechanical Q-factor, Q_{ms}	: 2.7
Electrical Q-factor, Q_{es}	: 0.27
Total Q-factor, Q_{ts}	: 0.24
Excursion, lin./max.	: $\pm 1.5 / \pm 5$ mm
Voice coil diameter	: 38 mm
Rated power handling	: 100 W (12 dB/oct. cross-over at 300 Hz)
Net weight	: 1.2 kg



Frequency response: 2.83V / 1m