

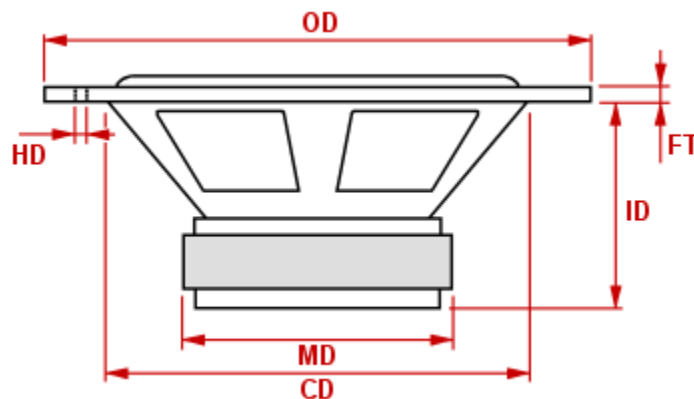

**vifa**
**XT18WH09-08**

Nominal impedance [ohm]	8
Voice coil resistance [ohm]	5.5
Nominal power [W]	-
Short term max power [W]	-
Long term max power [W]	-
Operating power [W]	-
Sensitivity [dB]	87
Frequency range [Hz]	-
Free air resonance [Hz]	38
Voice coil diameter [mm]	25
Voice coil height [mm]	14
Air gap height [mm]	4
Voice coil inductance [mH]	0.54
Eff. diaphragm Area [cm <sup>2</sup> ]	129
Moving mass [g]	10.7
Magnet weight [g]/[oz]	-
Force factor [BI]	5.5
VAS [l]	39
Q <sub>ms</sub>	1.38
Q <sub>es</sub>	0.46
Q <sub>ts</sub>	0.37

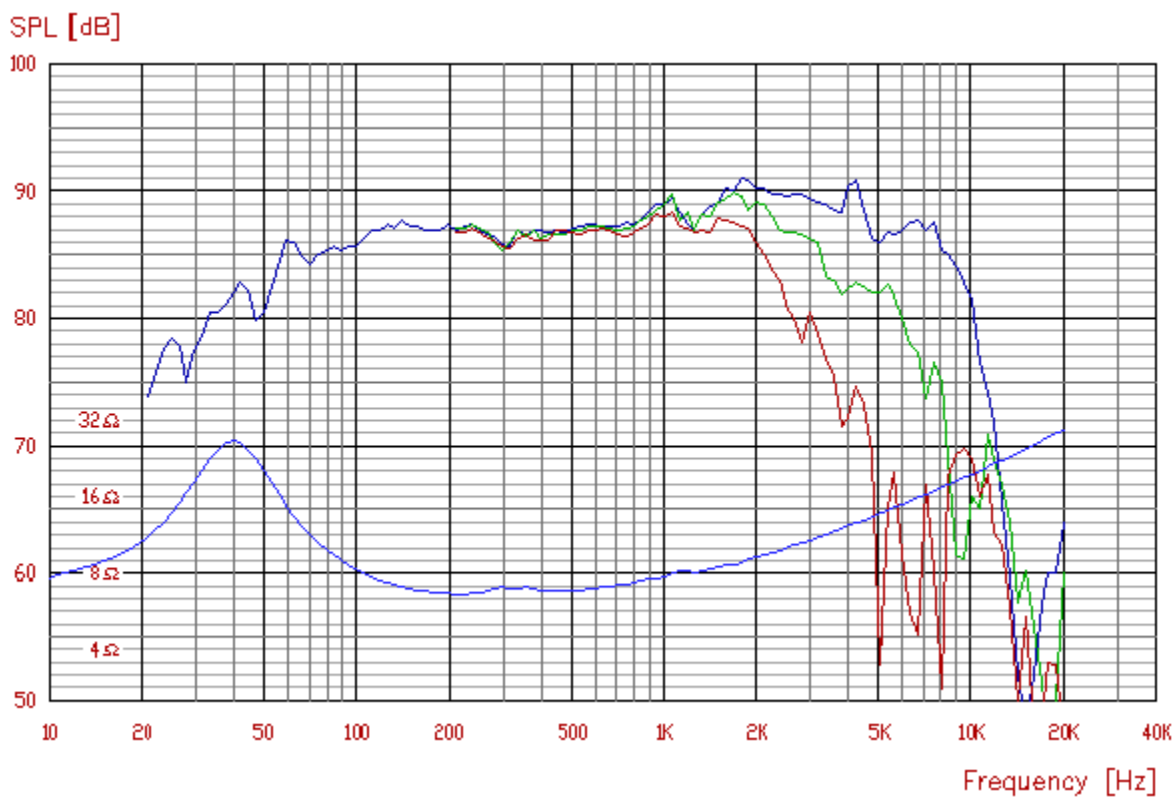

OD:	180 mm	CD:	147 mm
FT:	1.7 mm	ID:	76 mm
MD:	91.8 mm	HD:	6xø5.2@ø163



Frequency response: 2.83V / 1m