

Model Number: NE19VTA-04
Product Line: Peerless Platinum

Revision: Rev 2_0
Date: 3-Sep-09



Product Description:

The NE family has leading-edge transducer technology packaged in a cutting edge, stylistic design. The 4 ohm 19 mm tweeters in this family feature finite element analysis designed Neodymium-Iron-Boron magnet (NdFeB) motors, with copper caps for extended frequency response and reduced distortion. The aluminium rear chambers offer extended low frequency performance, while doubling as heat sinking. The butterfly supporting the tweeter diaphragm is made of a high temperature plastic, consistent with the product's high temperature performance rating, and features supporting terminals. The dome material in this design is aluminum, and the design has been optimized for sound quality and clarity. Rounding out the design is an aluminium face plate and plastic grille, which offers protection for the tweeter diaphragm.



Mechanical 2D Drawing:

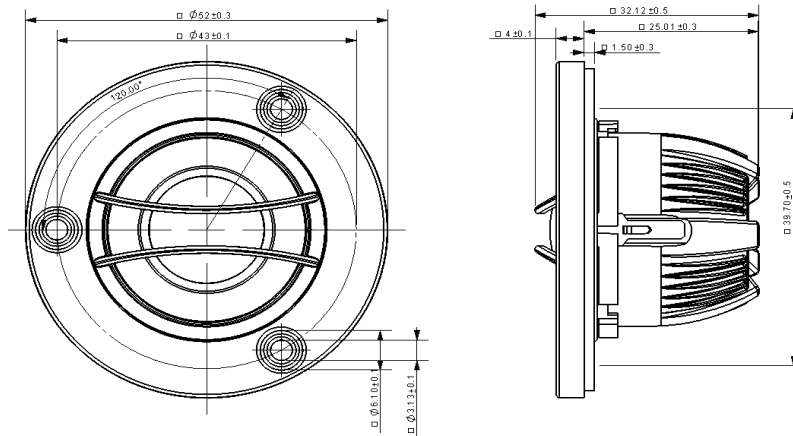

Specifications:

DC Resistance	R_{exc}	Ω	2.5	5.0%	Energy Bandwidth Product	EBP	$(1/Q_{\text{es}}) f_s$	451
Minimum Impedance	Z_{min}	Ω	3.1	7.5%	Moving Mass	M_{ms}	g	0.21
Voice Coil Inductance	L_e	mH	0.01		Suspension Compliance	C_{ms}	um/N	204.7
Resonant Frequency	f_s	Hz	775	15.0%	Effective Cone Diameter	D	cm	2.5
Mechanical Q Factor	Q_{ms}	-	2.8		Effective Piston Area	S_D	cm ²	4.9
Electrical Q Factor	Q_{es}	-	1.72		Equivalent Volume	V_{as}	L	0.01
Total Q Factor	Q_{ts}	-	1.07		Motor Force Factor	BL	T·m	1.22
Ratio f_s / Q_{ts}	F	f_s / Q_{ts}	724		Motor Efficiency Factor	β	$(T \cdot m^2) / \Omega$	0.58
Half Space Sensitivity @ 2.83V	dB@2.83V/1m	dB	89.4	+/-1.0 ¹	Voice Coil Former Material	VC _m	-	ASV
Sensitivity @ 1W/1m	1W/1m	dB	87.2	+/-1.0 ¹	Voice Coil Inner Diameter	VC _d	mm	19.3
					Gap Height	Gh	mm	2.0
Rated Noise Power (IEC 2685 18.1)	P	W	100		Maximum Linear Excursion	X_{max}	mm	0.10
Test Spectrum Bandwidth	2.5kHz - 20kHz		12 dB/Oct		Ferrofluid Type	FF		N/A
					Transducer Size	-	inch	0.75
					Transducer Mass	-	kg	0.06

1 - Piston Band Sensitivity Tolerance

Frequency and Impedance Response:

