

FE167E

Recommended Bass Reflex Type Enclosure

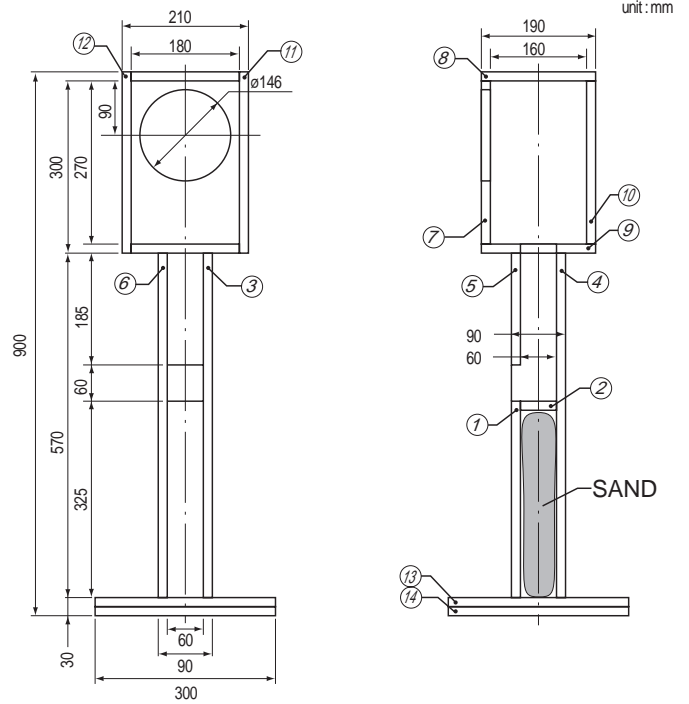

- Shown is an example of a FE167E bass reflex type enclosure.
- The stand serves as both speaker stand and bass reflex duct (port).
- Packing sand or other fill inside lower stand will improve stability and sound quality.
- This enclosure is designed to limit low frequency and realize flat frequency response at all bandwidths.

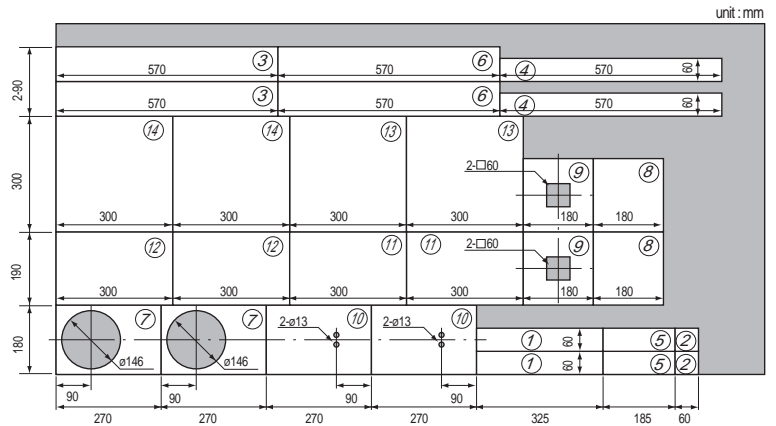

Frequency Response

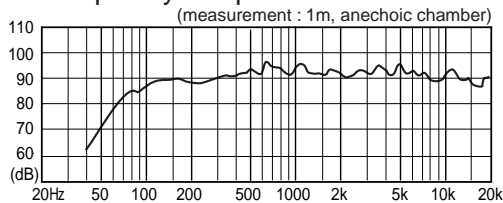

- Two way system using super tweeter is also recommended.
- 15mm thick plywood was used for the tested enclosure.

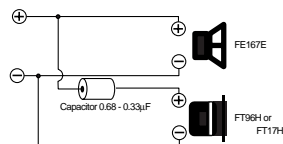

Standard Recommended Bass Reflex Type Enclosure

Example of FE167E standard bass reflex type enclosure. This enclosure has 15 liter capacity. You may try various external dimensions so long as internal volume remains the same.

